

**HANDHELD  
DIGITAL MULTIMETER**

**OPERATOR'S  
INSTRUCTION MANUAL**

<b>TITLE</b>	<b>PAGE</b>
<b>1. GENERAL INSTRUCTIONS</b>	<b>1</b>
1.1 Precaution safety measures	1
1.1.1 Preliminary	1
1.1.2 During use	2
1.1.3 Symbols	4
1.1.4 Instructions	5
<b>2. DESCRIPTION</b>	<b>6</b>
2.1 Instrument Familiarization	6
2.2 LCD Display	7
2.3 Key pad	9
2.4 Rotary switch	10
2.5 Terminals	11
2.6 Accessories	11
<b>3. FUNCTION DESCRIPTION</b>	<b>12</b>
3.1 General Functions	12
3.1.1 DATA HOLD mode	12
3.1.2 Manual ranging and Autorange mode	12
3.1.3 Battery saver	13
3.2 Measurement Functions	13
3.2.1 AC and DC Voltage measurement	13
3.2.2 Resistance measurement	14
3.2.3 Diode Test	16
3.2.4 Continuity Check	17
3.2.5 Capacitance measurement	17
3.2.6 Frequency measurement	18
3.2.7 Transistor measurement	19
3.2.8 Current measurement (with clamp, optional)	19
3.2.9 Current measurement	20

## Table of Contents

<b>TITLE</b>	<b>PAGE</b>
<b>4. TECHNICAL SPECIFICATIONS</b>	<b>21</b>
4.1 General specifications..	21
4.2 Measurement specifications	22
4.2.1 DC Voltage	22
4.2.2 AC Voltage	22
4.2.3 Resistance	23
4.2.4 Diode Test	23
4.2.5 Continuity Check	23
4.2.6 Transistor	23
4.2.7 Capacitance	24
4.2.8 Frequency	24
4.2.9 Current (with clamp, optional)	24
4.2.10 DC Current	25
4.2.11 AC Current	25
<b>5. MAINTENANCE</b>	<b>26</b>
5.1 General maintenance	26
5.2 Battery and fuse replacement	26
<b>6. HOW TO USE THE HOLSTER</b>	<b>27</b>

## 1. GENERAL INSTRUCTIONS

This instrument complies with IEC 1010-1 (61010-1@IEC: 2001), CAT. II 1000V and CAT. III 600V overvoltage standards. See Specifications.

To get the best service from this instrument, read carefully this user's manual and respect the detailed safety precautions. International symbols used on the Meter and in this manual are explained in chapter 1.1.3

### 1.1 Precautions safety measures

#### 1.1.1 Preliminary

\* Measurement category III is for measurements performed in the building installation.

NOTE: Examples are measurements on distribution boards, circuit-breakers, wiring, including cables, bus-bars, junction boxes, switches, socket-outlets in the fixed installation, and equipment for industrial use and some other equipment, for example, stationary motors with permanent connection to the fixed installation.

\* Measurement category II is for measurements performed on circuits directly connected to the low voltage installation.

NOTE: Examples are measurements on household appliances, portable tools and similar equipment.

\* Measurement category I is for measurements performed on circuits not directly connected to MAINS.

NOTE: Examples are measurements on circuits not derived from MAINS, and specially protected (internal) MAINS derived circuits. In the latter case, transient stresses are variable; for that reason, requires that the transient withstand capability of the equipment is made known to the user.

- \* When using this Multimeter, the user must observe all normal safety rules concerning:
  - protection against the dangers of electric current.
  - protection of the Multimeter against misuse.
- \* For your own safety, only use the test probes supplied with the instrument. Before use, check that they are in good condition.

### 1.1.2 During use

- \* If the meter is used near noise generating equipment, be aware that display may become unstable or indicate large errors.
- \* Do not use the meter or test leads if they look damaged.
- \* Use the meter only as specified in this manual; otherwise, the protection provided by the meter may be impaired.
- \* Use extreme caution when working around bare conductors or bus bars.
- \* Do not operate the meter around explosive gas, vapor, or dust.
- \* Verify a Meter's operation by measuring a known voltage. Do not use the Meter if it operates abnormally. Protection may be impaired. When in doubt, have the Meter serviced.
- \* Uses the proper terminals, function, and range for your measurements.
- \* When the range of the value to be measured is unknown, check that the range initially set on the multimeter is the highest possible or, wherever possible, choose the autoranging mode.
- \* To avoid damages to the instrument, do not exceed the maximum limits of the input values shown in the technical specification tables.
- \* When the multimeter is linked to measurement circuits, do not touch unused terminals.

- \* Caution when working with voltages above 60Vdc or 30Vac rms. Such voltages pose a shock hazard.
- \* When using the probes, keep your fingers behind the finger guards.
- \* When making connections, connect the common test lead before connecting the live test lead; when disconnecting, disconnect the live test lead before disconnecting the common test lead.
- \* Before changing functions, disconnect the test leads from the circuit under test.
- \* For all dc functions, including manual or auto-ranging, to avoid the risk of shock due to possible improper reading, verify the presence of any ac voltages by first using the ac function. Then select a dc voltage range equal to or greater than the ac range.
- \* Before attempting to insert transistors for testing, always be sure that test leads have been disconnected from any measurement circuits.
- \* Components should not be connected to the hFE socket when making voltage measurements with test leads.
- \* Disconnect circuits power and discharge all high-voltage capacitors before testing resistance, continuity, diodes, or capacitance.
- \* Never perform resistance or continuity measurements on live circuits.
- \* Before measuring current, check the meter's fuse and turn off power to the circuit before connecting the meter to the circuit.
- \* In TV repair work, or when carrying out measurements on power switching circuits, remember that high amplitude voltage pulses at the test points can damage the multimeter. Use of a TV filter will attenuate any such pulses.

- \* Use the 9V NEDA battery, properly installed in the Meter's battery case, to power the Meter.
- \* Replace the battery as soon as the battery indicator (  ) appears. With a low battery, the Meter might produce false readings that can lead to electric shock and personal injury.
- \* Do not measure voltages above 600V in Category III, or 1000V in Category II installations.
- \* Do not operate the Meter with the case (or part of the case) removed.

### 1.1.3 Symbols:

Symbols used in this manual and on the instrument:



**Caution:** refer to the instruction manual. Incorrect use may result in damage to the device or its components.



Dangerous voltage may be present.



AC (Alternating Current)



DC (Direct Current)



Earth ground



Double insulated



Fuse



Conforms to European Union directives

### 1.1.4 Instructions

- \* Remove test leads from the Meter before opening the Meter case or battery cover.
- \* When servicing the Meter, use only specified replacement parts.
- \* Before opening up the instrument, always disconnect from all sources of electric current and make sure you are not charged with static electricity, which may destroy internal components.
- \* Any adjustment, maintenance or repair work carried out on the meter while it is live should be carried out only by appropriately qualified personnel, after having taken into account the instructions in this present manual.
- \* A "qualified person" is someone who is familiar with the installation, construction and operation of the equipment and the hazards involved. He is trained and authorized to energize and de-energize circuits and equipment in accordance with established practices.
- \* When the instrument is opened up, remember that some internal capacitors can retain a dangerous potential even after the instrument is switched off.
- \* If any faults or abnormalities are observed, take the instrument out of service and ensure that it cannot be used until it has been checked out.
- \* If the meter is not going to be used for a long time, take out the battery and do not store the meter in high temperature or high humidity environment.

## 2. DESCRIPTION

### 2.1 Instrument Familiarization

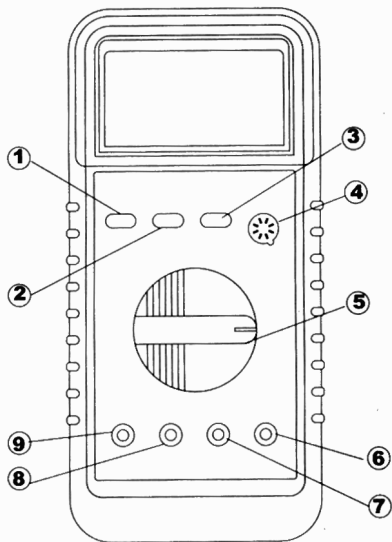

- ① Range Control Button
- ② Data Hold Button
- ③ AC/DC Current or  $\mu A$  /  $\rightarrow$  Selecting Button
- ④ Socket for Transistor Test
- ⑤ Function Switch/Power Switch
- ⑥ V/ $\Omega$ /F/Cx Input Jack
- ⑦ COM Input Jack
- ⑧ mA  $\rightarrow$  Input Jack
- ⑨ 10A Input Jack

### 2.2 LCD Display

See Table 1 indicated for information about the LCD display.

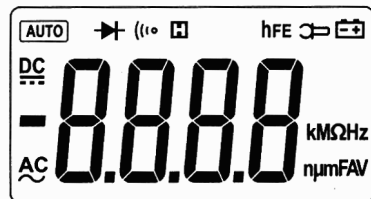

Table 1. Display Symbols

Symbol	Meaning
	The battery is low. <b>⚠ Warning:</b> To avoid false readings, which could lead to possible electric shock or personal injury, replace the battery as soon as the battery indicator appears.
-	Indicates negative readings.
	Indicator for ac voltage or current. AC voltage and current are displayed as the average of the absolute value of the input, calibrated to indicate the equivalent rms value of a sine wave.
	Indicator for dc voltage or current.
AUTO	The Meter is in the Autorange mode in which the meter automatically selects the range with the best resolution.

**Table 1. Display Symbols (continued)**

Symbol	Meaning
	Indicator for the Diode Test mode
hFE	Indicator for the transistor test mode
	Indicator for the Continuity Check mode.
	Indicator for the Data Hold mode
V, mV	V: Volts. The unit of voltage. mV: Millivolt. $1 \times 10^{-3}$ or 0.001 volts.
A, mA, $\mu$ A	A: Amperes (amps). The unit of current. mA: Milliamp. $1 \times 10^{-3}$ or 0.001 amperes. $\mu$ A: Microamp. $1 \times 10^{-6}$ or 0.000001 amperes
$\Omega$ , k $\Omega$ , M $\Omega$	$\Omega$ : Ohm. The unit of resistance. k $\Omega$ : Kiloohm. $1 \times 10^3$ or 1000 ohms. M $\Omega$ : Megohm. $1 \times 10^6$ or 1,000,000 ohms.
Hz, kHz, MHz	Hz: Hertz. The unit of frequency in cycles/second. kHz: Kiloherzt. $1 \times 10^3$ or 1000 hertz. MHz: Megahertz. $1 \times 10^6$ or 1,000,000 hertz.
$\mu$ F, nF	F: Farad. The unit of capacitance. $\mu$ F: Microfarad. $1 \times 10^{-6}$ or 0.000001 farads. nF: Nanofarad. $1 \times 10^{-9}$ or 0.000000001 farads.
	The input is too large for the selected range.

### 2.3 Keypad

See Table 2 indicated for information about the keypad operations.



**Table 2. Keypad**

Key	Function	Operation performed
	 A mA $\mu$ A <b>Power-up Option</b>	Switches between Diode Test and Continuity check. Switches between dc and ac current. <i>Disables automatic power-off feature.</i>
DATA-H	Any switch position	Press <b>HOLD</b> to enter and exit the Data Hold mode.
RANGE	V $\sim$ , V $\overline{\sim}$ , $\Omega$ , , mA and $\mu$ A.	<ol style="list-style-type: none"> <li>1. Press <b>RANGE</b> to enter the manual ranging mode.</li> <li>2. Press <b>RANGE</b> to step through the ranges available for the selected function.</li> <li>3. Press and hold <b>RANGE</b> for 2 seconds to return to autoranging.</li> </ol>

## 2.4 Rotary switch

See Table 3 indicated for information about the rotary switch positions.

**Table 3. Rotary Switch Positions**

Switch Position	Function
V~	AC Voltage measurement
V---	DC Voltage measurement
$\Omega$	Resistance measurement
 <small>on)</small>	Diode Test / Continuity Check
Cap	Capacitance measurement
Hz	Frequency measurement
hFE	Transistor measurement
	Measurement with clamp (optional), widening the field of applications of the multimeter
$\mu\text{A}$	DC or AC current measurements from 0.1 $\mu\text{A}$ to 4000 $\mu\text{A}$ .
mA	DC or AC current measurements from 0.01mA to 400mA.
A	DC or AC Current measurement from 0.01A to 10.00A.

## 2.5 Terminals

See Table 4 indicated for information about the terminals.

**Table 4. Terminals**

Terminal	Description
COM	Return terminal for all measurements. (Receiving the black test lead or the "com" plug of the optional clamp)
V $\Omega$ FCx	Input for voltage, resistance, frequency, Capacitance, diode and continuity measurements. (Receiving the red test lead)
mA 	Input for 0.1 $\mu\text{A}$ to 400mA current measurements. (Receiving the red test lead or the "+" plug of the optional clamp)
A	Input for 400mA to 10A current measurements. (Receiving the red test lead)

## 2.6 Accessories

Delivered with the multimeter:

- User's manual
- Test leads
- Holster

Optional:

- Clamp



### 3. FUNCTION DESCRIPTION

#### 3.1 General Functions

##### 3.1.1 DATA HOLD mode

Data Hold mode makes the meter stop updating the display. Enabling Data Hold function in autorange mode makes the meter switch to Manual ranging mode, but the full-scale range remains the same. Data Hold function can be cancelled by changing the measurement mode, pressing **RANGE** key, or push **HOLD** key again.

To enter and exit the Data Hold mode:

1. Press **HOLD** key (short press). Fixes the display on the current value, "H" is displayed.
2. A second short press returns the meter to normal mode.

##### 3.1.2 Manual ranging and Autorange mode

The Meter has both manual ranging and autorange options.

- \* In the autorange mode, the Meter selects the best range for the input detected. This allows you to switch test points without having to reset the range.
- \* In the manual ranging mode, you select the range. This allows you to override autorange and lock the meter in a specific range.
- \* The Meter defaults to the autorange mode in measurement functions that have more than one range. When the Meter is in the autorange mode, **AUTO** is displayed.

To enter and exit the manual range mode:

1. Press **RANGE** key. The Meter enters the manual ranging mode. **AUTO** turns off. Each presses of **RANGE** key increments the range. When the highest range is reached, the Meter wraps to the lowest range.

*NOTE: If you manually change the measurement range after entering the Data Hold modes, the Meter exits this mode.*

2. To exit the manual ranging mode, press and hold down **RANGE** key for two seconds. The Meter returns to the autorange mode and **AUTO** is displayed.

##### 3.1.3 Battery Saver

The Meter enters the "sleep mode" and blanks the display if the Meter is on but not used for 30 minutes.

Press the **HOLD** key or rotate the rotary switch to wake the meter up.

To disable the Sleep mode, hold down the  key while turning the meter on.

#### 3.2 Measurement Functions

##### 3.2.1 AC and DC Voltage measurement

 *To avoid electrical shock and/or damage to the instrument, do not attempt to take any voltage measurement that might exceed 1000Vdc or 750Vac rms.*

*To avoid electrical shock and/or damage to the instrument, do not apply more than 1000Vdc or 750Vac rms between the common terminal and the earth ground.*

The polarity of ac (alternating current) voltage varies over time; the polarity of dc (direct current) voltage is constant.

The Meter's DC voltage ranges are 400.0mV, 4.000V, 40.00V, 400.0V and 1000V ; AC voltage ranges are 400.0mV , 4.000V, 40.00V, 400.0V and 750V.

(AC 400.0mV range only exists in manual ranging mode).

To measure ac or dc voltage:

1. Set rotary switch to the DCV or ACV range.
2. Connect the black and red test leads to the COM and V terminals respectively.
3. Connect the test leads to the circuit being measured
4. Read the displayed value. The polarity of red test lead connection will be indicated when making a DCV measurement.

**NOTE:**

- Unstable display may occur especially at 400mV range, even though you do not put test leads into input terminals, in this case, if an erroneous reading is suspected, short the V terminal and the COM terminal, and make sure the zero display.
- For better accuracy when measuring the dc offset of an ac voltage, measure the ac voltage first. Note the ac voltage range, then manually select a dc voltage range equal to or higher than the ac range. This improves the accuracy of the dc measurement by ensuring that the input protection circuits are not activated.

**3.2.2 Resistance measurement**

 **To avoid electrical shock and/or damage to the instrument, disconnect circuit power and discharge all high-voltage capacitors before measuring resistance.**

The unit of resistance is the ohm ( $\Omega$ ). The Meter measures resistance by sending a small current through the circuit. Because this current flows through all possible paths between the probes, an in-circuit resistance reading represents the total resistance of all paths between the probes.

The Meter's resistance ranges are 400.0 $\Omega$ , 4.000k $\Omega$ , 40.00k $\Omega$ , 400.0k $\Omega$ , 4.000M $\Omega$  and 40.00M $\Omega$ .

To measure resistance:

1. Set the rotary switch to  $\Omega$  range.
2. Connect the black and red test leads to the COM and  $\Omega$  terminals respectively.
3. Connect the test leads to the circuit being measured and read the displayed value.

Some tips for measuring resistance:



- The measured value of a resistor in a circuit is often different from the resistor's rated value. This is because the Meter's test current flows through all possible paths *between the probe tips*.
- In order to ensure the best accuracy in measurement of low resistance, short the test leads before measurement and memory the test probe resistance in mind. This necessary to subtract for the resistance of the test leads.
- The resistance function can produce enough voltage to forward-bias silicon diode or transistor junctions, causing them to conduct. To avoid this, do not use the 40M $\Omega$  range for in-circuit resistance measurements.
- On 40M $\Omega$  range, the meter may take a few seconds to stabilize reading. This is normal for high resistance measuring.
- When the input is not connected, i.e. at open circuit, the figure "OL" will be displayed for the overrange condition.

### 3.2.3 Diode Test

**⚠ To avoid electrical shock and/or damage to the instrument, disconnect circuit power and discharge all high-voltage capacitors before testing diodes.**

Use the diode test to check diodes, transistors, and other semiconductor devices. The diode test sends a current through the semiconductor junction, then measures the voltage drop across the junction. A good silicon junction drops between 0.5V and 0.8V.

To test a diode out of a circuit:

1. Set the rotary switch to   $\infty$  range.
2. Press the  $\infty$ / key to activate Diode Test.
3. Connect the black and red test leads to the COM and  $V\Omega$  terminals respectively.
4. For forward-bias readings on any semiconductor component, place the red test lead on the component's anode and place the black test lead on the component's cathode.
5. The meter will show the approx. forward voltage of the diode.

In a circuit, a good diode should still produce a forward bias reading of 0.5V to 0.8V; however, the reverse-bias reading can vary depending on the resistance of other pathways between the probe tips.



### 3.2.4 Continuity Check

**⚠ To avoid electrical shock and/or damage to the instrument, disconnect circuit power and discharge all high-voltage capacitors before testing for Continuity.**

Continuity is a complete path for current flow.

The beeper sounds if a circuit is complete. These brief contacts cause the Meter to emit a short beep.

To test for continuity:

1. Set the rotary switch to   $\infty$  range.
2. Press the  $\infty$ / key to activate Continuity Check.
3. Connect the black and red test leads to the COM and  $\Omega$  terminals respectively.
4. Connect the test leads to the resistance in the circuit being measured.
5. When the test lead to the circuit is below 50 $\Omega$ , a continuous beeping will indicate it.

**Note:**

- \* Continuity test is available to check open/short of the circuit.

### 3.2.5 Capacitance measurement

**⚠ To avoid electrical shock and/or damage to the instrument, disconnect circuit power and discharge all high-voltage capacitors before measuring capacitance. Use the dc voltage function to confirm that the capacitor is discharged.**

Capacitance is the ability of a component to store an electrical charge.

The unit of capacitance is the farad (F). Most capacitors are in the nanofarad to microfarad range. The Meter measures capacitance by charging the capacitor with a known current for a known period of time, measuring the resulting voltage, then calculating the capacitance. The measurement takes about 1 second per range.

The Meter's capacitance ranges are 4.000nF, 40.00nF, 400.0nF, 4.000 $\mu$ F, 40.00 $\mu$ F and 200.0 $\mu$ F.

To measure capacitance:

1. Set the rotary switch to **Cap** range.
2. Connect the black and red test leads to the **COM** and **Cx** terminals respectively.
3. Connect the test leads to the capacitor being measured and read the displayed value.

#### Some tips for measuring capacitance:

- \* The meter may take a few seconds (200 $\mu$ F range, 30 seconds) to stabilize reading. This is normal for high capacitance measuring.
- \* To improve the accuracy of measurements less than 4nF, subtract the residual capacitance of the Meter and leads.

### 3.2.6 Frequency measurement

**⚠ Do not measure Frequency on high voltage (>250V) to avoid electrical shock hazard and/or damage to the instrument.**

1. Set the rotary switch to **Hz** range.
2. Connect the black and red test leads to the **COM** and **Hz** terminals respectively.
3. Connect the test leads across the source or load under measurement, and read the displayed value.

#### Note:

- \* In noisy environment, it is preferable to use shield cable for measuring small signal.



### 3.2.7 Transistor measurement

**⚠ To avoid electrical shock and/or damage to the instrument, before attempting to insert transistors for testing, always be sure that test leads have been disconnected from any measurement circuits.**

1. Set the rotary switch to **hFE** range.
2. Determine whether the transistor to be tested is NPN or PNP type and locate the Emitter, Base and Collector leads.
3. Insert leads of the transistor into proper holes of the hFE socket.
4. The meter will show the approx. hFE value at test condition of base current 10 $\mu$ A and Vce 2.8V.

### 3.2.8 Current measurement (with clamp, optional)

**⚠ To avoid electrical shock and/or damage to the instrument, do not apply more than 250Vdc or 250Vac rms between the  terminal and the COM terminal.**

1. Set the rotary switch to the  range.
2. Press  $\overline{\sim}/\sim$  key to select DCA or ACA measuring mode.
3. Connect the leads of the clamp to the **COM** and  terminals of the meter.
4. Read the displayed value. The polarity of the V $\Omega$  terminal connection will be indicated when making a DCA measurement.
5. When only the figure "OL" displayed, it indicates overrange situation.

### 3.2.9 Current measurement

**⚠ To avoid damage to the Meter or injury if the fuse blows, never attempt an in-circuit current measurement where the open-circuit potential to earth is greater than 250V.**

**To avoid damage to the meter, check the meter's fuse before proceeding. Use the proper terminals, function, and range for your measurement. Never place the probes in parallel with a circuit or component when the leads are plugged into the current terminals.**

The Meter's current ranges are 400.0 $\mu$ A, 4000 $\mu$ A, 40.00mA, 400.0mA, and 10.00A.

To measure current:

1. Turn off power to the circuit. Discharge all high voltage capacitors.
2. Set the rotary switch to the  $\mu$ A, mA or A range.
3. Press the  $\leftrightarrow/\sim$  key to select DCA or ACA measuring mode.
4. Connect the black test lead to the COM terminal and the red test leads to the mA terminal for a maximum of 400mA. For a maximum of 10A, move the red test lead to the A terminal.
5. Break the circuit path to be tested.  
Touch the black probe to the more negative side of the break; touch the red probe to the more positive side of the break. (Reversing the leads will give a negative reading, but will not damage the Meter.)
6. Turn on power to the circuit; then read the display. Be sure to note the measurement units at the right side of the display ( $\mu$ A, mA or A). When only the figure "OL" displayed, it indicates overrange situation and the higher range has to be selected.

7. Turn off power to the circuit and discharge all high voltage capacitors. Remove the Meter and restore the circuit to normal operation.

## 4 TECHNICAL SPECIFICATIONS

### 4.1 GENERAL SPECIFICATIONS

- \* Environment conditions:  
1000V CAT. II and 600V CAT. III  
Pollution degree: 2  
Altitude < 2000m  
Operating temperature:  
0~40 $^{\circ}$ C, 32 $^{\circ}$ F~122 $^{\circ}$ F (<80% RH, <10 $^{\circ}$ C non-condensing)  
Storage temperature:  
-10~60 $^{\circ}$ C, 14 $^{\circ}$ F~140 $^{\circ}$ F (<70% RH, battery removed)
- \* Temperature Coefficient:  
0.1 $\times$ (specified accuracy) /  $^{\circ}$ C (<18 $^{\circ}$ C or >28 $^{\circ}$ C)
- \* MAX. Voltage between terminals and earth ground:  
750V AC rms or 1000V DC.
- \* Fuse Protection:  
 $\mu$ A and mA: F 500mA/250V  $\varnothing$ 5 $\times$ 20;  
10A: F 10A/250V  $\varnothing$ 6.3 $\times$ 32.
- \* Sample Rate: 3 times/sec for digital data.
- \* Display:  
3 3/4 digits LCD display. Automatic indication of functions and symbols.
- \* Range selection: automatic and manual.
- \* Over Range indication: LCD will display "OL".
- \* Low battery indication:  
The " $\text{---}$ " is displayed when the battery is under the proper operation range.
- \* Polarity indication: "-" displayed automatically.
- \* Power source: 9V  $\text{---}$

- Battery type: NEDA 1604, 6F22, or 006P.
- Dimensions: 91(L)×189(W)×31.5(H) mm.
- Weight: 310g. Approx. (battery included).

#### 4.2 Measurement specifications

Accuracy is specified for one year after calibration, at operating temperatures of 18°C to 28°C, with relative humidity at 0% to 75%.

Accuracy specifications take the form of: ± (% of Reading + Number of Least Significant Digits)

##### 4.2.1 DC Voltage

Range	Resolution	Accuracy
400mV	0.1mV	± (0.7% of rdg +2 digits)
4V	1mV	
40V	10mV	
400V	100mV	
1000V	1V	± (0.8% of rdg +2 digits)

Input impedance: 10MΩ

Max. input voltage: 1000Vdc or 750V ac rms.

##### 4.2.2 AC Voltage

Range	Resolution	Accuracy
400mV	0.1mV	±(3.0% of rdg + 3 digits)
4V	1mV	± (0.8% of rdg +3 digits)
40V	10mV	
400V	100mV	
750V	1V	± (1.0% of rdg +3 digits)

Input impedance: 10MΩ

Max. input voltage: 1000Vdc or 750V ac rms.

Frequency Range: 40Hz-200Hz for 4V range, 40Hz-1kHz for other ranges.

Response: Average, calibrated in rms of sine wave

##### 4.2.3 Resistance

Range	Resolution	Accuracy
400.0Ω	0.1Ω	± (1.2%% of rdg +2 digits)
4.000kΩ	1Ω	
40.00kΩ	10Ω	
400.0kΩ	100Ω	
4.000MΩ	1kΩ	± (2.0% of rdg +5 digits)
40.00MΩ	10kΩ	

Overload protection: 250V dc or 150Vac rms.

Open Circuit Voltage: approx. 250mV.

##### 4.2.4 Diode

Range	Resolution	Function
	1mV	Display read approx. forward voltage of diode

Forward DC Current: approx. 1mA

Reversed DC Voltage: approx. 1.5V

Overload protection: 250Vdc or 150Vac rms.

##### 4.2.5 Audible continuity

Range	Continuity beeper
	≤50Ω

Sound circuit voltage: approx.0.5V.

Overload protection: 250Vdc or 250Vac rms.

##### 4.2.6 Transistor

Range	Description	Test Condition
hFE	Display read approx. HFE value (0-1000) of transistor under test (all type).	Base Current approx. 10μA, Vce approx. 2.8V.

#### 4.2.7 Capacitance

Range	Resolution	Accuracy
4nF	1pF	±(5.0% of rdg+5 digits)
40nF	10pF	
400nF	100pF	±(3.0% of rdg+3 digits)
4μF	1nF	
40μF	10nF	
200μF	100nF	

Overload protection: 250Vdc or 250Vac rms.

#### 4.2.8 Frequency

Range	Resolution	Accuracy
9.999Hz	0.001 Hz	±(2.0% of rdg+5 digits)
99.99Hz	0.01 Hz	
999.9Hz	0.1 Hz	
9.999kHz	1Hz	
99.99kHz	10Hz	
199.9kHz	100Hz	Unspecified @ >200kHz
>200kHz	100Hz	

Overload protection: 250V dc or 250V ac rms.

Input Voltage range: 0.6V-3V ac rms (Input voltage must be enlarged with increasing frequency under measurement)

Frequency Response: 10Hz-200kHz, sine wave.  
0.5Hz-200kHz, square wave.

#### 4.2.9 Current (with clamp, optional)

Range	Resolution	Accuracy
DC40A	0.1A/1mV	±(0.8% of rdg+3 digits)
DC400A	0.1A/1mV	±(0.8% of rdg+3 digits)
AC40A	0.1A/1mV	±(1.0% of rdg+3 digits)
AC400A	0.1A/1mV	±(1.0% of rdg+3 digits)

Input impedance: 1MΩ

Max. input voltage: 250Vdc or 250Vac rms.

#### 4.2.10 DC CURRENT

Range	Resolution	Accuracy
400μA	0.1μA	±(1.2% of rdg+3 digits)
4000μA	1μA	
40mA	0.01mA	
400mA	0.1mA	
10A	10mA	±(2.0% of rdg+5 digits)

Overload protection: F 10A/250V fuse for A range. F 500mA/250V fuse for μA and mA ranges.

Maximum input current: 400mA dc or 400mA ac rms for μA and mA ranges, 10A dc or 10A ac rms for A ranges.

For measurements>5A, 4 minutes maximum ON to measure 10 minutes OFF.

#### 4.2.11 AC CURRENT

Range	Resolution	Accuracy
400μA	0.1μA	±(1.5% of rdg+5 digits)
4000μA	1μA	
40mA	0.01mA	
400mA	0.1mA	
10A	10mA	±(3.0% of rdg+7 digits)

Overload protection: F 10A/250V fuse for A range.

F 500mA/250V fuse for μA and mA ranges.

Maximum input current: 400mA dc or 400mA ac rms for μA and mA ranges, 10A dc or 10A ac rms for A ranges.

Frequency Range: 40Hz-1kHz

Response: Average, calibrated in rms of sine wave

## 5. MAINTENANCE

This section provides basic maintenance information, including fuse and battery replacement instructions.

Do not attempt to repair or service your Meter unless you are qualified to do so and have the relevant calibration, performance test, and service information.

### 5.1 General Maintenance

 **To avoid electrical shock or damage to the meter, do not get water inside the case. Remove the test leads and any input signals before opening the case**

Periodically wipe the case with a damp cloth and mild detergent. Do not use abrasives or solvents.

Dirt or moisture in the terminals can affect readings.

To clean the terminals:

- \* Turn the meter off and remove all test leads.
- \* Shake out any dirt that may be in the terminals.
- \* Soak a new swab with a cleaning and oiling agent (such as WD-40).
- \* Work the swab around in each terminal. The oiling agent insulates the terminals from moisture-related contamination.

### 5.2 Battery and fuse replacement

If the sign "" appears on the LCD display, it indicates that the battery should be replaced. Remove screws on the back cover and open the case. Replace the exhausted battery with a new one.

Fuse rarely need replacement and blow almost always as a result of the operator's error. Open the case as mentioned above, and then take the PCB assembly out from the case. Replace the blown fuse with ratings specified.

## WARNING

*Before attempting to open the case, be sure that test leads have been disconnected from measurement circuits to avoid electric shock hazard.*

*For protection against fire, replace fuse only with specified ratings: F1: F 500mA/250V F2: F 10A/250V*

## 6. HOW TO USE THE HOLSTER

The holster is used to protect the meter and to make the measurement more comfortable. It comes with two stands installed together. The following figure shows how to use the holster to:

- Support the meter with a standard angle.
- Support the meter with a small angle using the little stand
- Hang the meter on the wall using the little stand. Take the little stand off from the backside of the large stand and insert it into holes located upper on the holster.
- Hold test leads.

## CAUTION:

*"Using this appliance in an environment with a strong radiated radio-frequency electromagnetic field (approximately 3V/m), may influence its measuring accuracy. The measuring result can be strongly deviating from the actual value"*



HYS005597